

Our Seaoptic LumiO lights, are designed for use above and underwater.  
With flicker free LED technology, and 100% dimmable.\*  
They are well suited for wellboats, fishing vessels and other maritime applications.  
Produced in stainless steel with a hygienic design, the housing can tolerate extreme environment.  
Gaskets, cables and glass are made of ozone resistant materials.  
Our lights can easily replace Wibre and Fupe.  
Internal high quality LED driver for easy 230VAC installation.  
All lights are delivered with fixed cable lengths of either 20M, 50M or 80M\*\*  
The luminaires are tested by third party for their compliance to CE and standards like IEC 62031 and IEC 60598. They can also be supplied with UL certificate upon request.

\*Dimmable on request

\*\*Other cable lengths on request

## KEY SPECIFICATIONS

Ingress protection code	IP68
Light source	LED
Power (max)	60W
Lumen	7200l
Luminaire efficacy	120lm/W
Optics	Lens 120 degree*
Voltage range	100-240V
Freq range	50/60Hz

\*Different beam on request



ABOVE AND  
BELOW  
WATER

[www.seaoptic.no](http://www.seaoptic.no)



# LumiO

WELLIGHT 230V 60W FIXED

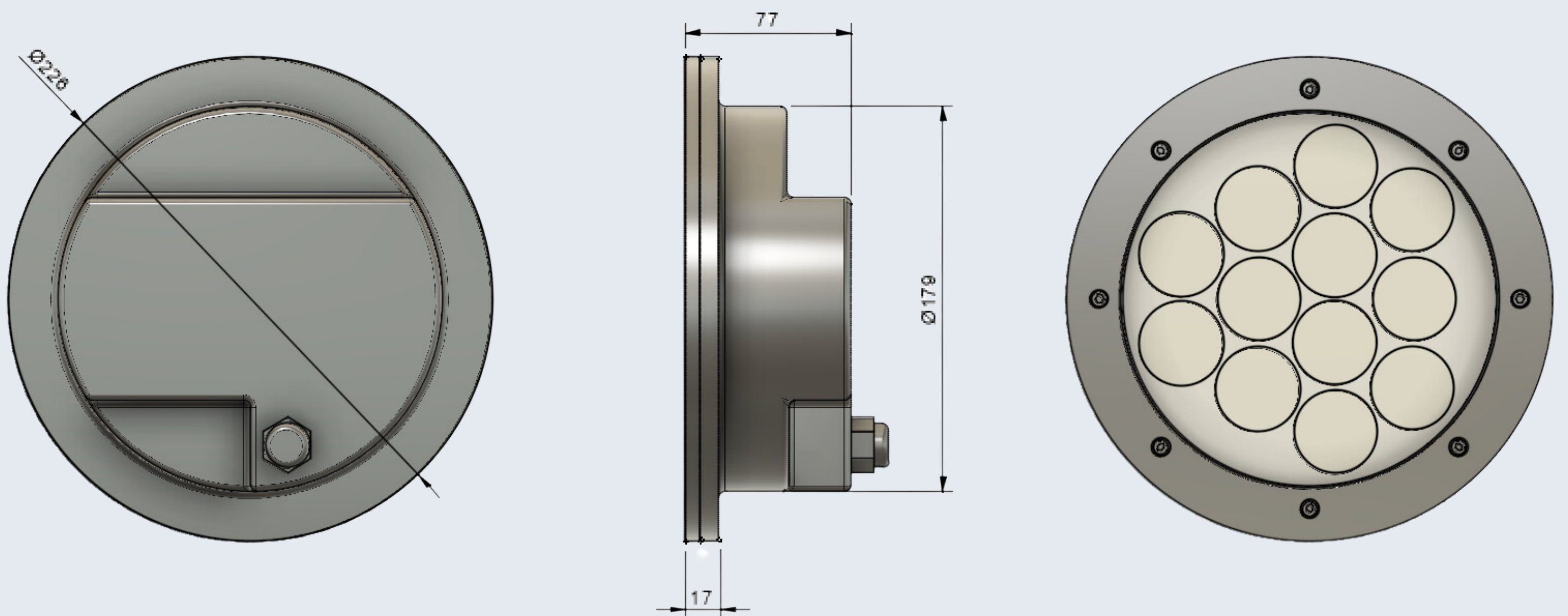
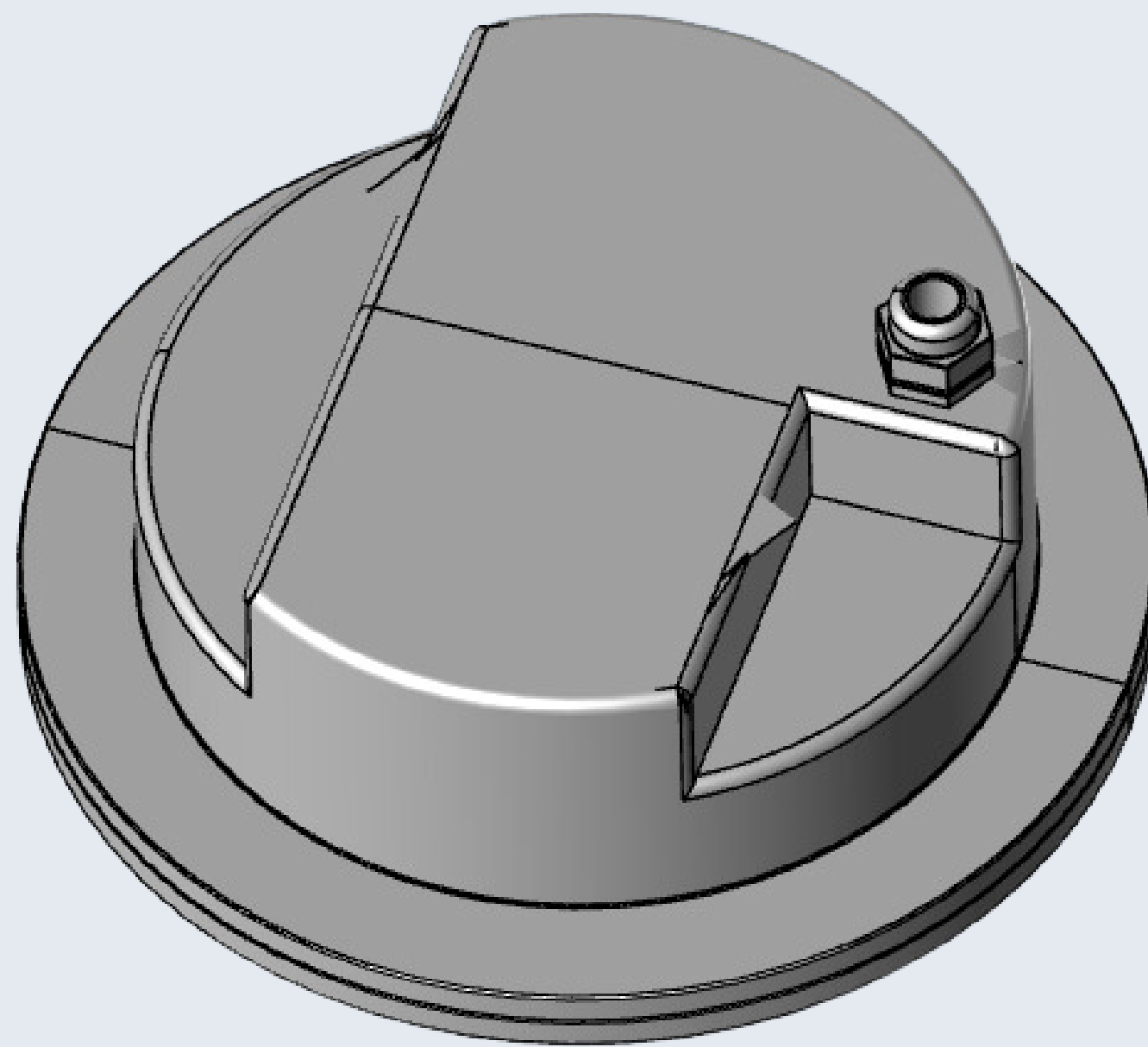

LumiO

SUBMERSIBLE LIGHTS

# LumiO

WELLIGHT 230V 60W FLUSH

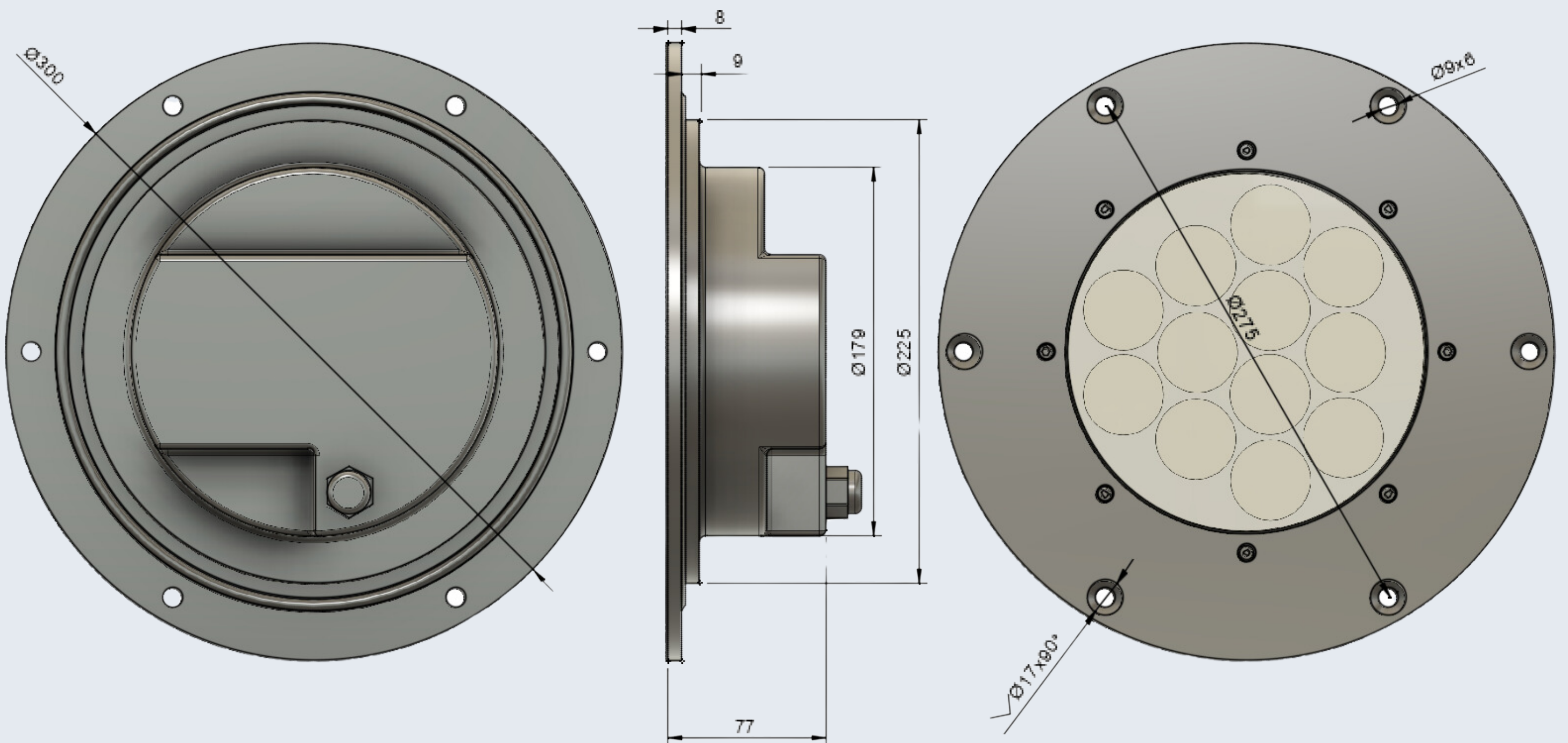
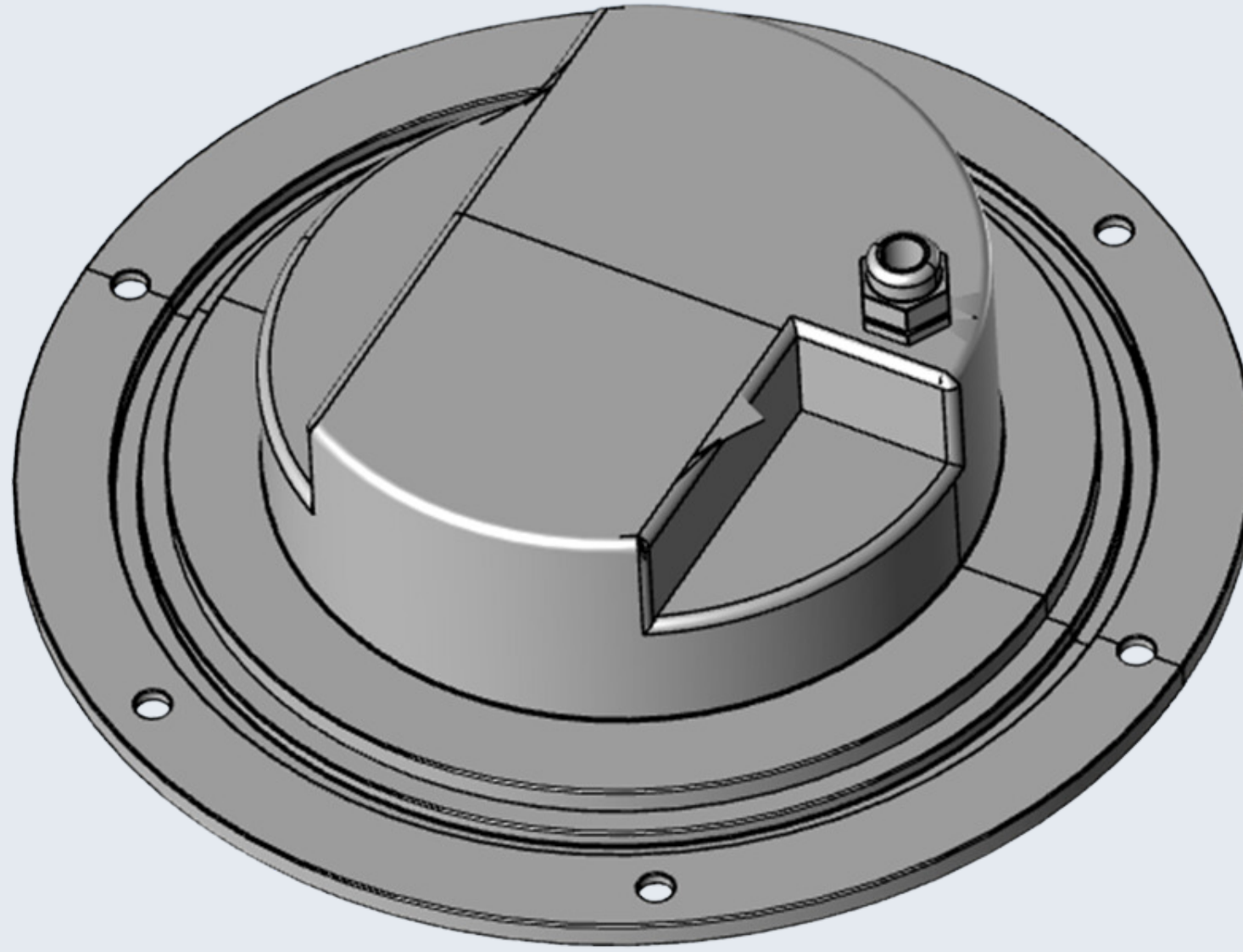

LumiO

SUBMERSIBLE LIGHTS